

Introduction

Features and Functions

The iLux™ units, CLSI-C6 and CLSI-C6M, are wall-mounted complete integrated lighting systems that can function as standalone devices and/or be part of a Crestron® solution total control system network (Cresnet®). The units are functionally identical except that the CLSI-C6M includes a built-in motion sensor.

CLSI-C6M with Cover Open, Shown in Almond



Each unit provides automated control of up to six channels of lighting loads, including incandescent, magnetic low-voltage, neon/cold cathode, and non-dimmable loads. Each unit also provides automated control of up to six groups of shade and drape controllers for motorized window treatments, screens, and lifts.

Front panel operation provides manual control of lighting loads and shade groups as well as access to up to sixteen scenes (lighting level/shade position combinations).

A built-in IR receiver allows for wireless operation using an optional infrared remote generating standard RC5 commands; a built-in motion detector (CLSI-C6M only) enables automated control based on room occupancy.

Up to 16 Crestron keypads (sold separately) can be used with each unit for control of rooms that have several entrances or work areas. Each unit also supports up to eight additional CLSI-C6 units, enabling systems of up to 54 lighting channels and 54 shade groups.

Each unit provides control system integration through two separate Cresnet control networks; one for local devices and one for connection to a 2-Series control system.

Each unit is available in three colors: almond, black, or white. The letter at the end of the product name, 'A', 'B', or 'W', denotes the color (e.g., a CLSI-C6MA is an almond unit).

Specifications

Following are specifications for the iLux units.

CLSI-C6 & CLSI-C6M Specifications

SPECIFICATION	DETAILS
Power Requirements	Line Power, 230 VAC, 50/60Hz
Load Ratings ¹	
Max load per channel:	800 W/VA (3.5 Amps @ 230 VAC)
Min load per channel:	25 W/VA (0.108 Amps @ 230 VAC)
Max load per unit:	2300 W/VA (10 Amps @ 230 VAC)
Load Types ¹	Incandescent, magnetic low voltage, neon/cold cathode, and non-dim lighting.
IR Receiver	For use with Crestron IR remote (sold separately).
Motion Detector (CLSI-C6M only)	
Type	Infrared
Range	20 to 30 feet at 4-foot elevation (6 to 9 meters at 1.2 meter elevation)
Default Net ID	1F
Control System Update Files ^{2,3}	2-Series Control System
Firmware	Version 2.004.CUZ or later
Cooling Requirement	63 BTU/Hr (approximate)
Environmental Temperature	32° to 104°F (0° to 40°C)
Humidity	10% to 90% RH (non-condensing)
Overall Dimensions:	
Height	4.48 in (11.38 cm)
Width	8.89 in (22.58 cm)
Depth	2.47 in (6.25 cm) for CLSI-C6 2.60 in (6.61 cm) for CLSI-C6M
Weight	22.8 oz (646.37 g)

1. Additional load types can be controlled and load ratings can be increased via optional CLS-EXP expansion modules. Refer to the Crestron website <http://www.crestron.com> for details.

2. The latest versions can be obtained from the Crestron website. Refer to NOTE after last footnote.

3. Crestron 2-Series control systems include the AV2 and PRO2. Consult the latest Crestron Product Catalog for a complete list of 2-Series control systems.

NOTE: Crestron software and any files on the website are for Authorized Crestron dealers and Crestron Authorized Independent Programmers (CAIP) only. New users may be required to register to obtain access to certain areas of the site (including the FTP site).

Physical Description

The following illustration shows the overall dimensions for the CLSI-C6 and CLSI-C6M.

CLSI-C6M Overall Dimensions

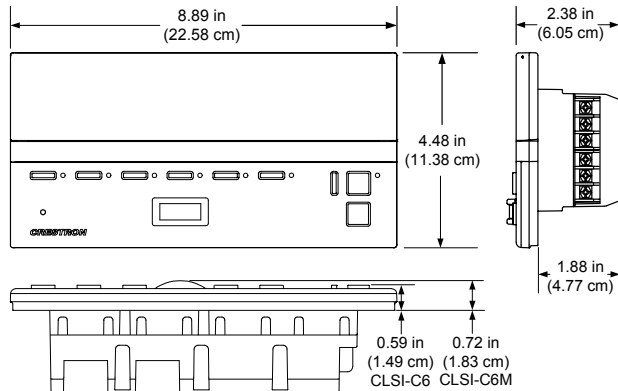

Industry Compliance

These units have been designed to comply with IEC 60669-2-1 and specifications for CE marking. Formal approval is pending.

Important Notes

Read before installation.

- **Codes:** Install in accordance with all local and national electrical codes.
- **Wiring:** Use copper wire only. For supply connections, use wires rated for at least 75°C.
- **Lighting Load Types:** incandescent, magnetic low voltage, neon/cold cathode, and non-dim lighting.
- **Temperature:** The iLux units are designed for use where temperatures are between 32° to 104°F (0° to 40°C).
- **Wallboxes:** The iLux units mount in standard 4-gang wallboxes; 3.5 inches deep, minimum.
- **Make certain that power is turned off,** and ensure that there is at least 12 inches of open space above and below the electrical box location to permit heat dissipation.

Installation

WARNING: Turn off power at the distribution panel circuit breaker. Installing with power on can result in serious personal injury and damage to the device.

CAUTION: To reduce the risk of overheating and possible damage to other equipment, do not install to control a receptacle or a motor-operated appliance.

NOTE: The CLSI-C6 units require a neutral wire for operation. If no neutral is present, contact a licensed electrician for installation.

The following tools/hardware are required for installation.

- A 4-gang electrical box (not supplied), 3.5 inches deep, minimum.
- Phillips torque screwdriver (not supplied)
- Four 7/8-inch pan head Phillips screws (supplied)

If the planned configuration includes connection to shade controllers, keypads, and/or a Crestron 2-Series control system, the following items are also required. Refer to the latest version of the Crestron CLSI-C6 & CLSI-C6M iLux Lighting System Operations Guide, Doc. 6347, for detailed configuration options.

- Cresnet network cable(s) (not supplied)
- Terminal block connector(s) (two supplied)

Check that any required Cresnet wiring has been installed and verified. Then, use the following procedure to install the iLux unit (CLSI-C6M is shown in the illustrations).

1. Feed the wires (power line from the distribution panel, load wires, plus any required Cresnet cables) through the holes in the wallbox. Then install the box in the wall.
2. Hold the rear of the CLSI-C6M unit and remove the front panel and cover assembly by carefully pulling out and up from the bottom edge.

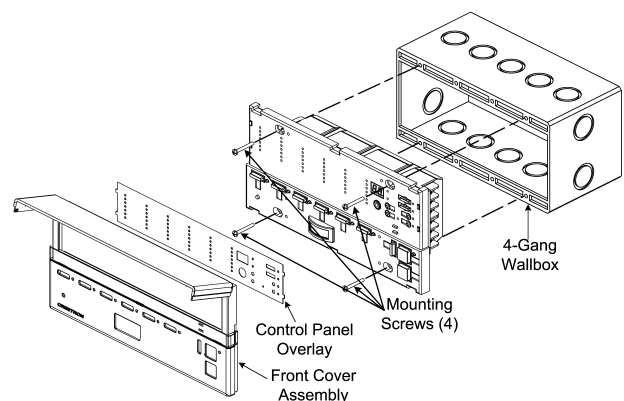

3. Remove the control panel overlay from the unit (it lifts off – is held in place by small tabs) to reveal the upper mounting screw holes.
4. Refer to the following diagram for connection of the AC wiring. All wires to be inserted in the screw terminals should be stripped 7/16-inch, and screws should be tightened to between 8 and 10 in.-lbs. (0.90 Newton meters to 1.13 Newton meters). The maximum wire size is 12 AWG (3 mm²).

- Connect each load wire to the corresponding LOAD terminals on the unit, connect the power line hot wire from the circuit breaker to the HOT terminal on the unit, connect all neutral wires to the NEUTRAL terminal on the unit, and connect all ground wires to the \oplus (ground) terminal on the unit.
- If Cresnet cabling is part of the installation, attach the supplied terminal block connector(s) to the Cresnet cable(s) and plug into the appropriate port(s) on the unit. Make certain that there is a minimum 1/4-inch (0.6 cm) separation

between the Class 2 Cresnet wiring and the Class 1 AC wiring.

- Carefully tuck all wires into the wallbox and fasten the unit to the wallbox using the four 7/8-inch Phillips screws supplied.
- Reattach the control panel overlay to the front panel by inserting the four tabs into the slots provided, and install the hinged front cover assembly by lining it up at the top and pressing the bottom edge until it snaps into position.

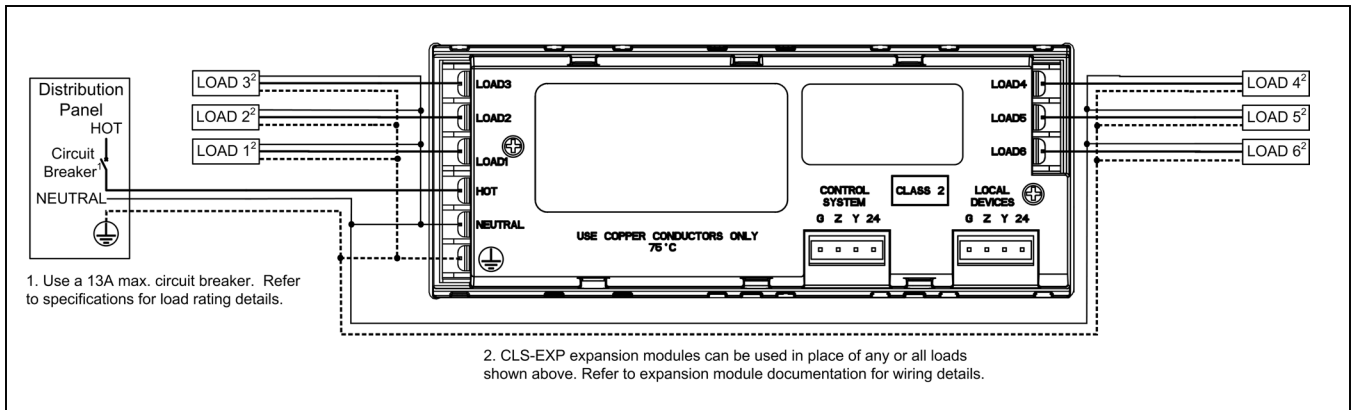

Power up and Testing

The following illustration shows the front panel of the unit and the controls used during installation.

Front Panel Controls and Indicators

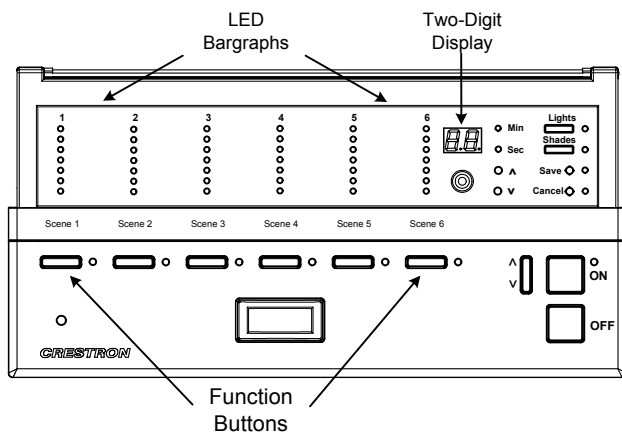

Verify the basic installation and wiring connections as follows:

- Press the **Lights** button to enable manual light control, and press the right side and the left side of each of the function buttons to increase and decrease the lighting level of those loads. Verify that the intended loads and corresponding LED bargraphs respond appropriately.
- Press the **OFF** button to turn off all loads. The loads will ramp down to off while the two-digit display counts down to off (blank). Two seconds after all lights have turned off, the unit's master air-gap relay opens making it safe to service the lighting installations.

Problem Solving

Troubleshooting

The table after this paragraph provides corrective action for possible trouble situations. If further assistance is required, please contact a Crestron customer service representative.

CLSI-C6/C6M Installation Troubleshooting

TROUBLE	POSSIBLE CAUSE(S)	CORRECTIVE ACTION
Unit does not function.	Unit is not receiving line power.	Verify that the unit is properly connected to the power line and that the circuit breaker is closed.
	Loads are not connected.	Verify that the loads are operational and that they are connected to the iLux unit.
Loads turn on and off, but do not dim.	Wrong load type settings.	Correct load type settings. *
Lights flicker at low levels	Incorrect low-end limit setting.	Change low-end limit setting. *

* Refer to the latest version of the Crestron CLSI-C6 & CLSI-C6M iLux Lighting System Operations Guide, Doc. 6347, for details on setting load types and low-end limits.

Further Inquiries

If you cannot locate specific information or have questions after reviewing this guide, please take advantage of Crestron's award winning customer service team by calling Crestron at 1-888-CRESTRON [1-888-273-7876].

You can also log onto the online help section of the Crestron website (www.crestron.com/onlinehelp) to ask questions about Crestron products. First-time users will need to establish a user account to fully benefit from all available features.

Future Updates

As Crestron improves functions, adds new features, and extends the capabilities of the CLSI-C6 and CLSI-C6M, additional information may be made available as manual updates. These updates are solely electronic and serve as intermediary supplements prior to the release of a complete technical documentation revision.

Check the Crestron website periodically for manual update availability and its relevance. Updates are identified as an "Addendum" in the Download column.

Return and Warranty Policies

Merchandise Returns / Repair Service

- No merchandise may be returned for credit, exchange, or service without prior authorization from CRESTRON. To obtain warranty service for CRESTRON products, contact an authorized CRESTRON dealer. Only authorized CRESTRON dealers may contact the factory and request an RMA (Return Merchandise Authorization) number. Enclose a note specifying the nature of the problem, name and phone number of contact person, RMA number, and return address.
- Products may be returned for credit, exchange, or service with a CRESTRON Return Merchandise Authorization (RMA) number. Authorized returns must be shipped freight prepaid to CRESTRON, 6 Volvo Drive, Rockleigh, N.J. or its authorized subsidiaries, with RMA number clearly marked on the outside of all cartons. Shipments arriving freight collect or without an RMA number shall be subject to refusal. CRESTRON reserves the right in its sole and absolute discretion to charge a 15% restocking fee, plus shipping costs, on any products returned with an RMA.
- Return freight charges following repair of items under warranty shall be paid by CRESTRON, shipping by standard ground carrier. In the event repairs are found to be non-warranty, return freight costs shall be paid by the purchaser.

CRESTRON Limited Warranty

CRESTRON ELECTRONICS, Inc. warrants its products to be free from manufacturing defects in materials and workmanship under normal use for a period of three (3) years from the date of purchase from CRESTRON, with the following exceptions: disk drives and any other moving or rotating mechanical parts, pan/tilt heads and power supplies are covered for a period of one (1) year; touchscreen display and overlay components are covered for 90 days; batteries and incandescent lamps are not covered.

This warranty extends to products purchased directly from CRESTRON or an authorized CRESTRON dealer. Purchasers should inquire of the dealer regarding the nature and extent of the dealer's warranty, if any.

CRESTRON shall not be liable to honor the terms of this warranty if the product has been used in any application other than that for which it was intended, or if it has been subjected to misuse, accidental damage, modification, or improper installation procedures. Furthermore, this warranty does not cover any product that has had the serial number altered, defaced, or removed.

This warranty shall be the sole and exclusive remedy to the original purchaser. In no event shall CRESTRON be liable for incidental or consequential damages of any kind (property or economic damages inclusive) arising from the sale or use of this equipment. CRESTRON is not liable for any claim made by a third party or made by the purchaser for a third party.

CRESTRON shall, at its option, repair or replace any product found defective, without charge for parts or labor. Repaired or replaced equipment and parts supplied under this warranty shall be covered only by the unexpired portion of the warranty.

Except as expressly set forth in this warranty, CRESTRON makes no other warranties, expressed or implied, nor authorizes any other party to offer any warranty, including any implied warranties of merchantability or fitness for a particular purpose. Any implied warranties that may be imposed by law are limited to the terms of this limited warranty. This warranty statement supersedes all previous warranties.

Trademark Information

All brand names, product names, and trademarks are the sole property of their respective owners. Windows is a registered trademark of Microsoft Corporation. Windows95/98/Me/XP/Vista and WindowsNT/2000 are trademarks of Microsoft Corporation.